



## FEATURES



### POWERFUL AND CONSISTENT FLUID CIRCULATION

Equipped with three centrifugal pumps, the MFS 3500 delivers a steady and controlled flow, keeping the mud system balanced and providing optimal pressure for each stage of solids separation.



### ENHANCED MUD MIXING AND AGITATION

The combination of one stationary and two swivel mud guns ensures continuous agitation, preventing sedimentation and preserving uniform mud consistency for efficient drilling and improved mud quality.



### HIGH-EFFICIENCY SOLIDS SEPARATION

Two elliptical motion scalping shakers remove large particles quickly, while twelve 4-inch desilter hydrocyclones effectively capture fine solids, maintaining a clean, high-quality mud supply throughout operations.

## 600 GPM MUD FILTRATION SYSTEM 24-MICRON PARTICLE SEPARATION CAPABILITY

# MFS 3500

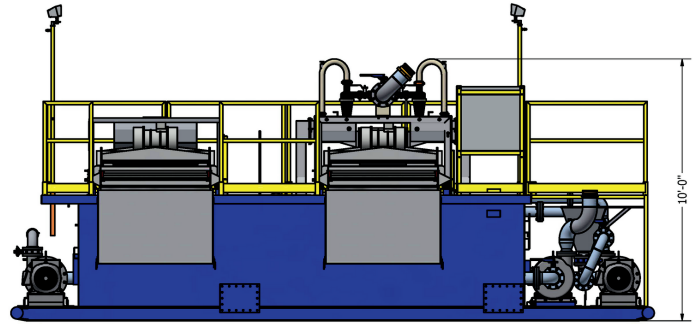
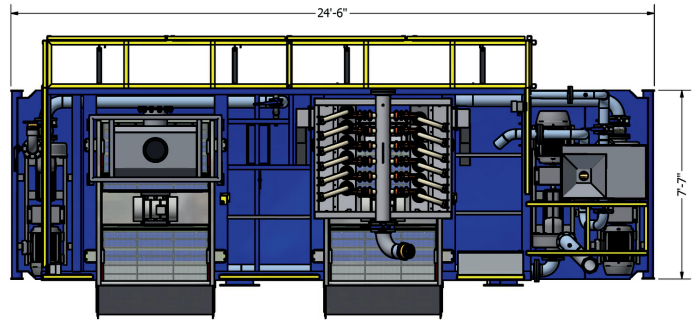
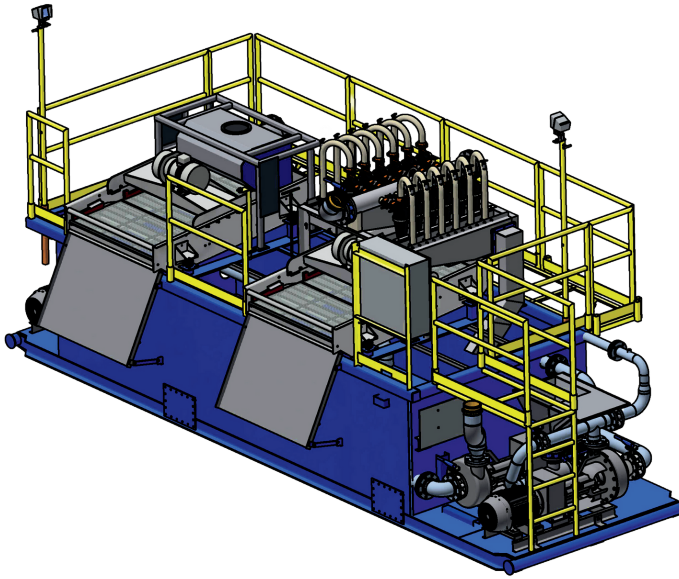

## EQUIPMENT

<b>SHAKERS</b>	2 TFI 146E Elliptical Motion Scalping Shakers 3 Screens Per Shaker Shaker Bed Area 24 ft <sup>2</sup> (2.3 m <sup>2</sup> ) Screen Size 25" x 49.3"
----------------	--

<b>DESILTERS</b>	12 4 in. (10.2 cm) Hydrocyclones
------------------	----------------------------------

<b>PUMPS</b>	2 4x5 250 Series Centrifugal Pumps with 30HP Electric Motors 1 4x5 250 Series Centrifugal Pump with 40HP Electric Motor
--------------	--

<b>MUD GUNS</b>	1 Stationary Mud Gun 2 Swivel Mud Guns
-----------------	---

<b>HOPPER</b>	1 TFI 4 in. Mud Hopper with Venturi Jet
---------------	---

## WEIGHT AND DIMENSIONS

<b>WEIGHT</b>	19500 lbs (8845 kg)
<b>LENGTH</b>	24 ft 6 in. (7.5 m)
<b>WIDTH</b>	7 ft 7 in. (2.3 m)
<b>HEIGHT</b>	10 ft (3 m)

## TANK CAPACITIES

<b>MAX CAPACITY</b>	3228 gal (12.22 kL)
<b># OF TANKS</b>	2
<b>SCALPER TANK</b>	1302 gal (4.93 kL)
<b>DESILTER TANK</b>	1926 gal (7.29 kL)

## GENERAL SPECIFICATIONS

<b>INLET SIZE</b>	4 in. (10.2 cm)
<b>OUTLET SIZE</b>	4 in. (10.2 cm)
<b>CONTROL PANEL</b>	Centralized Weatherproof NEMA 4x Control Panel
<b>POWER REQUIREMENTS</b>	147 AMPS
<b>CORROSION CONTROL</b>	Chemical/Abrasion Resistant Mastic Tank Lining
<b>FRAME TYPE</b>	Skidded
<b>LIGHTING</b>	2 Telescoping LED Work Lights

## OPTIONAL ADD-ONS

<b>PIT PUMP</b>	TFI 4 in. Semi-Submersible
<b>GENERATOR</b>	150kW 460v/60Hz
<b>TRAILER</b>	Gooseneck/Pintle/Integrated
<b>WIRED REMOTE</b>	Pit Pump/Charge Pump
<b>WINTERIZATION</b>	Tank Heaters, Pipe Insulation +
<b>BRANDING</b>	Custom Colors and Logos
<b>ELECTRICAL</b>	XP Package

TRIFLO INTERNATIONAL RESERVES THE RIGHT TO MAKE CHANGES IN ENGINEERING, DESIGN AND SPECIFICATIONS; ADD IMPROVEMENTS; OR DISCONTINUE MANUFACTURING AT ANY TIME WITHOUT NOTICE OR OBLIGATION. EQUIPMENT AND DEPICTIONS SHOWN ARE FOR ILLUSTRATIVE PURPOSES ONLY AND MAY DISPLAY OPTIONAL ACCESSORIES OR COMPONENTS SPECIFIC TO CERTAIN MARKETS OR REGIONS.

© 2025 TRIFLO INTERNATIONAL. ALL RIGHTS RESERVED. PRINTED IN THE U.S.A. PLEASE RECYCLE

